

Suction System Accessories

OPW 70 Vertical Check Valves (with Shear Groove)

Materials

Body: Cast iron with black Duragard® E-coating
Disc: M-19 Viton



Features

- ◆ **Low Pressure Drop**
- ◆ **M-19 Viton Seals** – on main poppet for compatibility with methanol-blended fuels and reliable sealing
- ◆ **Protective Shear Groove** – designed to reduce the possibility of damage to buried piping in the event the dispenser is knocked over
- ◆ **Thermal Relief Valve** – to reduce pressure build-up in suction pumps. Opens between 25 & 35 PSI (1.7 & 2.4 bar)
- ◆ **Compatible with 85% Ethanol (E85) or Methanol (M85)**

Additional Features (70S Model)

- ◆ **Stabilizer Mounting Bosses** – three bosses in the lower portion of the valve body allow for rigid mounting to stabilizer bars. Use FlexWorks mounting plate with appropriate stabilizer bar kit
- ◆ **Built-In Air-Test Port** – allows air testing of the entire pumping system without breaking the line. Also allows line to be drained from the valve to the tank (assuming there are no other check or foot valves below the 70S)

OPW Vertical Check Valves

OPW Vertical Check Valves are installed on suction system fuel lines directly below the inlet to the pump in the dispenser island to maintain prime. The 70 Series Valves feature a built-in shear groove, which helps minimize piping damage if the dispenser is pulled over or dislodged by collision. The single-poppet provides redundant protection from losing prime and are also available without shear grooves. OPW Vertical Check Valves are recommended for use on suction lines where the pressure does not exceed 34 feet of head (approximately 15 psi [1 bar]). 70 Series valves need 1/2" of mercury to activate the poppet.

Ordering Specifications

Model #	in.	mm	lbs.	kg
70-0070	1 1/2" NPT	38 mm	1.80	.8
70S-0075	1 1/2" NPT	38 mm	2.9	1.3

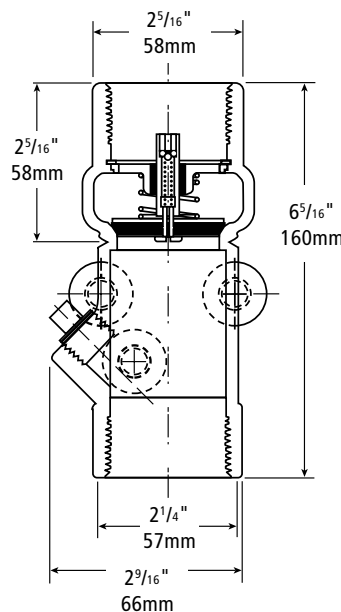
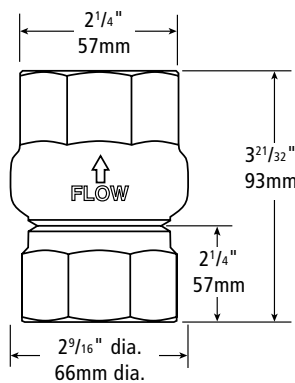

70 and 70S Vertical Check Valve Instruction Sheet
 Order Number: H11055PA

Warning: The valve body must be rigidly anchored to a structural member within the island to ensure breakage at the shear groove in the event of severe impact. The shear groove must be at the same level or a maximum of 1/2" above or below the top of the pedestal island. Failure to provide rigid mounting or install the shear groove at the proper level may result in a failure of the valve to close or shear, resulting in an excessive loss of product and a hazardous condition.